



COMPLETE MANUAL

WEIGHING INDICATOR TI-1200 and TI-1200-S

TI-1200 with rechargeable battery.



TI-1200-S without rechargeable battery and with a smaller cabinet.

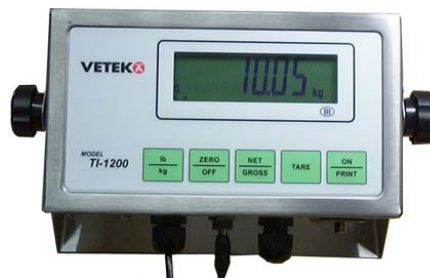

Note: When TI-1200 is shipped as a part of a complete Scale e.g. AV-250-series and AL-100-21, the Scales are normally calibrated. When TI-1200 is shipped together with Loadcells it is adjusted to the application but a calibration is always needed at the place of installation.

EC type-approved non-automatic weighing instrument Number FI 01.1.04

Accuracy class III



TABLE OF CONTENTS

	Page
INTRODUCTION TO THE TI-1200 DIGITAL INDICATOR	2
INSTALLATION TI-1200	3
INSTALLATION TI-1200-S	4
CONFIGURATION	6
CALIBRATION	11
SPECIFICATIONS	13
SERIAL PORT INFORMATION	14
DISPLAYED ERROR CODES AND FAULT LOCALIZATION	16
OPERATION	17

INTRODUCTION TO THE TI-1200 DIGITAL INDICATOR

TI-1200 Digital Indicator is a general purpose, industrial grade weight indicator.

TI-1200 comes with an internal 6V rechargeable battery, are capable of driving four 350 ohm load cells and operate identically. All readout up to 50,000 display divisions on a liquid crystal display (LCD) with back light. All set up parameters may be entered via the front panel keys, including calibration.

An external power supply is included. The external power supply functions (9 VDC) as a charger* for the rechargeable battery. The power supply may also be used as the main power supply.

TEST CERTIFICATE: Number FIT 01.I.02 class III

TI-1200 has 2 menus for configuration:

- Setup ("F") which configure the Indicator to your weighing application.
- User ("A") which configure the Indicator to the serial communication.

*Models:

TI-1200 : With rechargeable battery. Supply 9 VDC.

TI-1200-S : Without rechargeable battery. Supply 9 VDC. Smaller cabinet

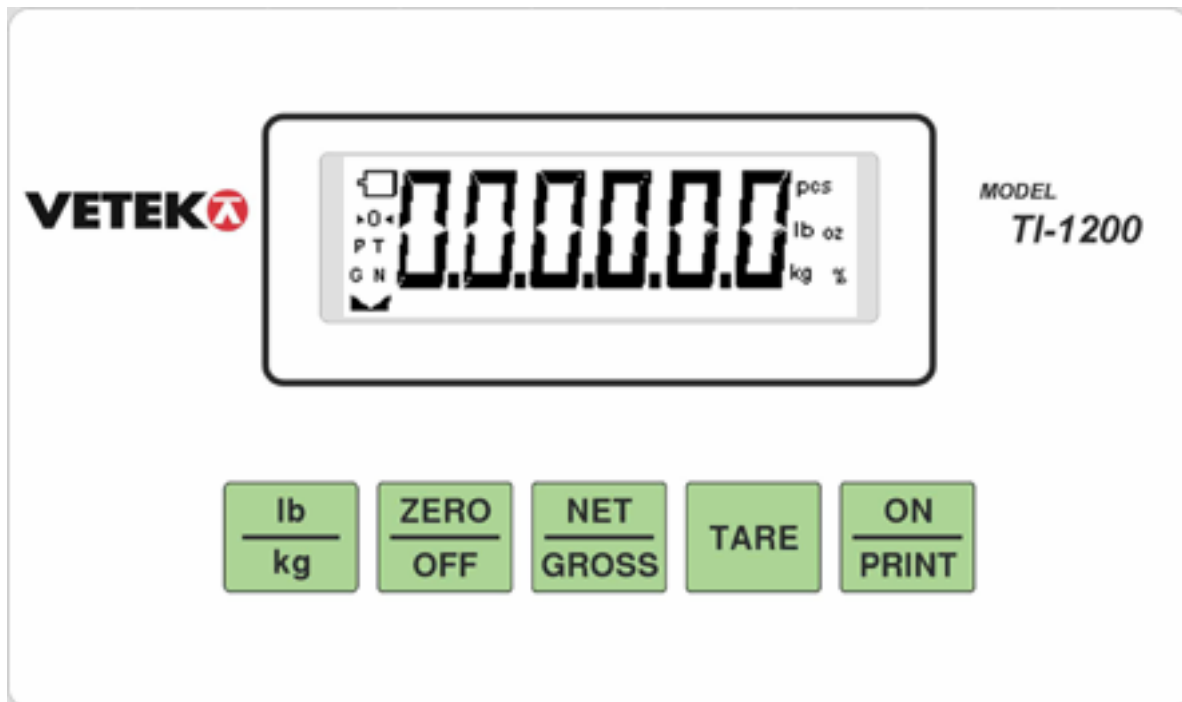

INSTALLATION TI-1200 (with battery)

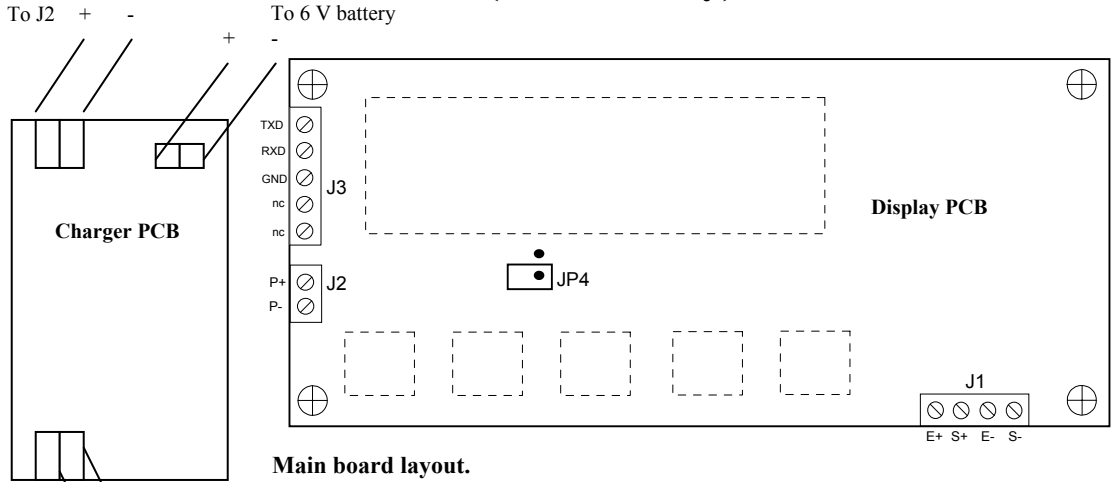

Main board layout.

When installing the back has to be removed. Could be mounted like this during installation.

Normal ↔ Calibration

The cable from calibration switch can be removed during installation



Automatic start: Short transistor Q1 between above two points.

For some applications is the charger board disconnected and the power is connected direct to J2. In this case the battery normally is removed.

If you want it is possible to demount the contact and connect the cable direct to battery charger or J2.
Note: +centre contact



The cable from the Loadcell (s) should be connected to J1. Remove a sufficient part of the external isolation to avoid strength on the wires. Colours, se next page. Connect the shield to E-

Note: Don't forget to connect the cable from calibration switch to JP4 when mounting the back.

INSTALLATION TI-1200-S (without battery)

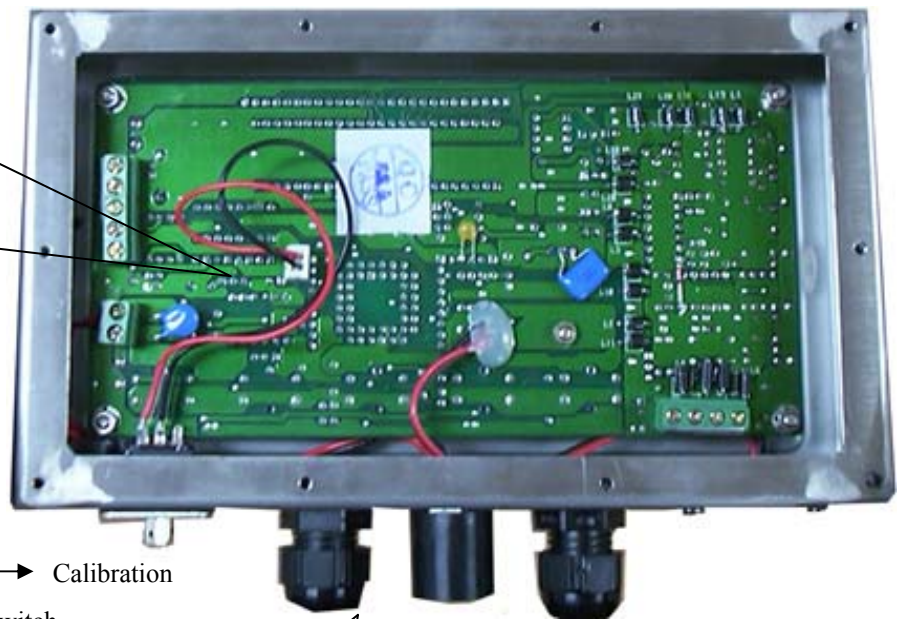
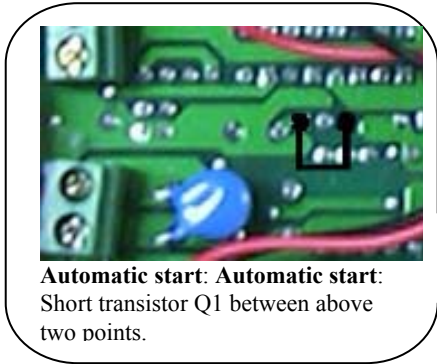
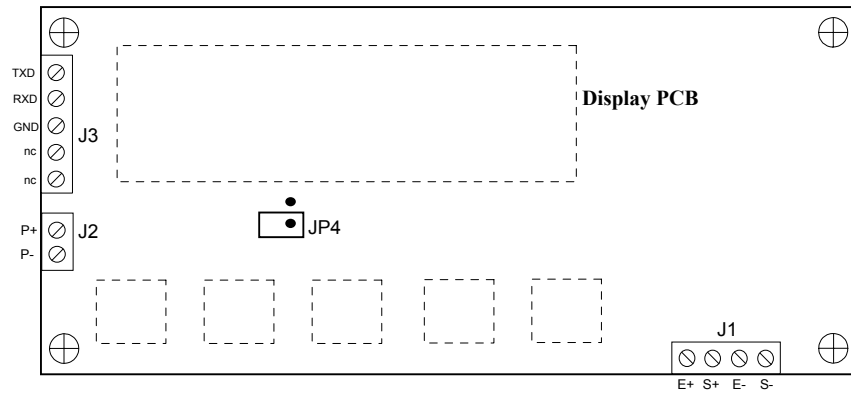

Normal ↔ Calibration
Calibration switch

If you want it is possible to demount the contact and connect the cable direct to battery charger or J2.
Note: +centre contact

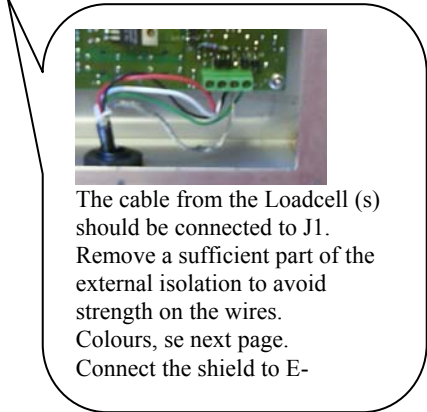

CONNECTING THE WEIGH PLATFORM / LOADCELL (s)

Connect your shielded load cell cable to terminal J1 on the main board.

Terminal J1

+ Excitation (Power to Loadcell)	E+
+ Signal Input	S+
- Excitation (Power to Loadcell)	E-
- Signal Input	S-

Loadcell	355	SB2	AKA	AG	1042
+ Input	Blue	Red	Red	Brown	Green
+ Output	White	Green	White	Yellow	Red
- Input	Black	White	Black	Green	Black
- Output	Red	Black	Yellow	White	White

E-, Cabinet or GND J3

If more than one Loadcells, all should be connected parallel.

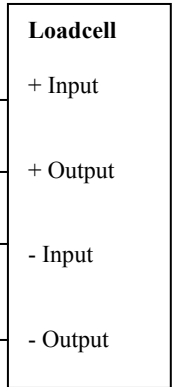

If S-Loadcells in tension the S+ and S- has to be shifted.

CONNECTING THE SERIAL PRINTER, REMOTE DISPLAY OR COMPUTER

The TI-1200 indicator comes standard with one full duplex RS-232 serial port, designed for connection to either a PC or a serial printer. The same port may be also used as a simplex, RS-232 port designed for connection to a remote display.

Connect your serial printer, remote display or computer communication cable (not included) to terminal J3 on the main board.

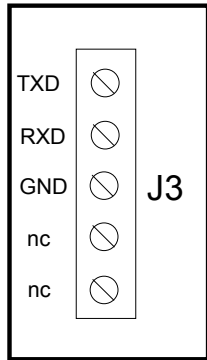

Figure 2-3: Connection assignments for the serial communication terminal

CONFIGURATION

OVERVIEW

The indicator contains two main setup menus: The Setup (“F”) menu which configures the indicator to your weigh platform and the User (“A”) menu which configures the serial communication port and enables some user options. The Setup and User menus consist of several menu selections, each with its own sub-menu of choices.

To set up the indicator, you must first enter the appropriate menu mode. Once there, four of the front panel keys become directional navigators to move around in the menus, and one key is used to save or SET the selections.

ENTERING THE SETUP MENU

1. Power off the indicator by **ZERO/OFF** in 3 seconds or by unplugging the power source
2. Set calibration switch in calibration mode (right position).
3. Power on the indicator by **ON/PRINT** or by plugging in the power source. The indicator shows ” F 1” to indicate that you are in Setup Menu mode.

NAVIGATING IN THE SETUP MENU

1. Use the directional keys shown in the Figure to move around in the Setup Menu Chart.
2. To move to the selection level, press **ZERO/OFF** (down) key once. The current saved selection is shown.
3. To move to a new “F” heading, use **TARE** (left) or **ON/PRINT** (right) key to move right or left in the Setup Menu Chart.
4. If you want to go back without saving press **lb/kg**.
5. If a digit flashing, use **lb/kg** and **ZERO/OFF** for choosing value.
6. To save a new selection, press the **NET/GROSS** (Set) key .To exit without saving, press the **PRINT** (up) key to return to the current “F” heading.
7. You can cancel calibration anytime with switching back to normal mode. An alternative is to disconnect the power.

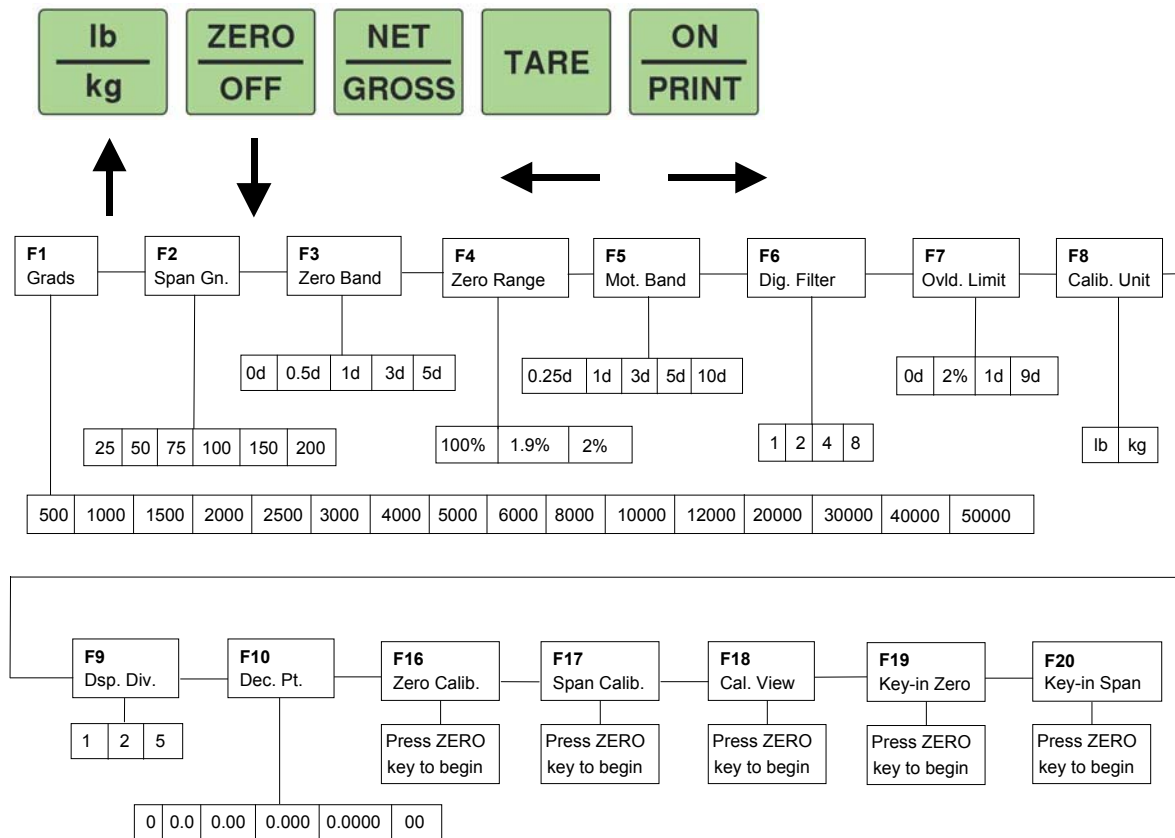

There is an **F21** sub-menu present that is for **FACTORY USE ONLY!**

The User (“A”) menu sub-menus appear when scrolling left or right from the “F” menu.

SETUP MENU DESCRIPTIONS AND PROCEDURES

Factory-set defaults are shown in **bold**.

NAME/CODE	DESCRIPTION	CODE/VALUE
F1 Graduations	Specifies number of full-scale graduations. Value should be consistent with legal requirements and environmental limits on the useful system resolution.	500 1,000 1,500 2,000 2,500 3,000 4,000 5,000 6,000 8,000 10,000 12,000 20,000 30,000 40,000 50,000
F2 Span Gain	Span Gain is related to A/D integration time. The larger the span gain, the higher the internal resolution, but the slower the update speed. Note that the scale must be re-calibrated whenever this parameter is altered. See Appendix C for more information.	25 50 75 100 150 200
F3 Zero Track Band	Selects the range within which the scale will automatically zero. Note that the scale must be in standstill to automatically zero. Selections are in Display Divisions.	0d 0.5d 1d 3d 5d
F4 Zero Range	Selects the range within which the scale may be zeroed. Note that the indicator must be in standstill to zero the scale.	100% (US) 1.9% (CE) 2%
F5 Motion Band	Sets the level at which motion is detected by comparing the present display update with the previous one. If motion is not detected for two seconds or more, scale is in standstill and can process a Print or Zero command. Maximum value varies depending on local regulations.	0.25d (CE) 1d (US) 3d 5d 10d
F6 Digital Filter	Averages weight readings to produce higher stability. The higher the filter setting, the greater the stability but the slower the indicator's response time. Choose 8 unless a very fast response is needed.	1 2 4 8
F7 Overload Limit	Selects the desired formula which determines the point at which the indicator shows overload. All selections are based on the primary unit selected in F8. "FS" = Full scale in primary units.	FS FS + 2% (US) FS + 1d FS + 9d (CE)
F8 Calib. Unit	Selects the primary base unit to be used in the calibration process. Also the default unit for normal operation. "1" = primary unit is lb. "2" = primary unit is in kg.	1 (US) 2 (CE)
F9 Display Divisions	Determines the desired weight increments. Value should be consistent with legal requirements.	1 2 5
F10 Decimal Pt.	Determines location of the decimal point.	0 0.0 0.00 0.000 0.0000 00
F16 Zero Calibration	Places indicator into the zero calibration routine. Scrolling down with the ZERO key one level begins the procedure.	Press ZERO key to begin sequence
F17 Span Calibration	Places indicator into the span calibration routine. Scrolling down with the ZERO key one level begins the procedure.	Press ZERO key to begin sequence
F18 View Calibration	Actuates the function that allows you to view both the zero and span calibration value. The values displayed in this function are valid only after Calibration (F16 & F17) has been successfully completed. Scrolling down with the ZERO key one level begins the procedure.	Press ZERO key to begin sequence
F19 Key-in Zero	Allows you to key-in known zero calibration value in case of memory loss in the field. Scrolling down with the ZERO key one level begins the procedure.	Press ZERO key to begin sequence
F20 Key-in Span	Allows you to key-in a known span calibration value in case of memory loss in the field. Scrolling down with the ZERO key one level begins the procedure.	Press ZERO key to begin sequence
F21 Factory Reset	This sub-menu will reset all parameters in the "F" and "A" menu to the default settings. USE WITH CAUTION!	Press the ZERO key twice to execute.



DETERMINING PROPER SPAN GAIN (F2)

Note: Normally done from factory.

OVERVIEW

The Span Gain parameter found in F2 of the Setup Menu is directly related to the ADC (Analog to Digital Converter) integration time. This means that the lower the setting, the higher the number of measurements per second. A span gain setting of **25** produces about 25 to 30 measurements per second, while a span gain of **200** produces only about 3 or 4 measurements per second.

There is really no wrong setting for span gain – except in two cases. Using a low setting for a high resolution, low output system could yield instability. Using a high setting in a high output system could yield non-linearity.

SETTING THE INITIAL VALUE FOR SPAN GAIN

1. Determine the number of desired external graduations and choose the corresponding value listed in Table C-1 under the number closest to your full-scale input range in millivolts.
2. Enter the Setup Menu and save this number for the Span Gain parameter in F2.
3. Perform a system calibration. If the calibration proves unsuccessful, or you wish to view the internal counts, proceed to the next set of instructions.

VIEWING THE INTERNAL COUNTS

1. Enter the zero calibration menu (F16) and follow steps 1 to 3, *but do not save the zero point*.
2. After pressing **ZERO** to zero the offset, place the test weight(s) on the platform. The displayed count is the internal count. If the count remains on zero, check your load cell connections.
3. At full scale, the displayed count should be a minimum of 2 times the desired external graduations. However, for maximum stability, a ratio of 6:1 or higher is recommended.
4. If the displayed count is large enough, remove the test weight(s), re-zero the indicator if necessary, and proceed with the calibration. If the displayed number is *not* large enough, increase the Span Gain to the next highest choice in the Setup Menu and re-calibrate.

External Grads	Full Scale Input Range (mV/V)														
	0.2	0.4	0.6	0.8	1.0	1.2	1.4	1.6	1.8	2.0	2.2	2.4	2.6	2.8	3.0
500	75	50	25	25	25	25	25	25	25	25	25	25	25	25	25
1,000	150	75	50	50	25	25	25	25	25	25	25	25	25	25	25
1,500	200	100	75	50	50	50	25	25	25	25	25	25	25	25	25
2,000	–	150	75	75	50	50	50	50	25	25	25	25	25	25	25
2,500	–	200	100	75	75	50	50	50	50	50	50	25	25	25	25
3,000	–	200	150	100	75	75	50	50	50	50	50	50	50	25	25
4,000	–	–	150	150	100	75	75	75	50	50	50	50	50	50	50
5,000	–	–	200	150	150	100	100	75	75	75	75	50	50	50	50
6,000	–	–	–	200	150	150	100	100	75	75	75	75	75	50	50
8,000	–	–	–	–	200	150	150	150	100	100	100	75	75	75	75
10,000	–	–	–	–	–	200	200	150	150	150	150	100	100	100	75
12,000	–	–	–	–	–	–	200	200	150	150	150	150	150	100	100
15,000	–	–	–	–	–	–	–	–	200	200	200	150	150	150	150
20,000	–	–	–	–	–	–	–	–	–	–	–	200	200	200	150
30,000	–	–	–	–	–	–	–	–	–	–	–	–	–	–	–
40,000	–	–	–	–	–	–	–	–	–	–	–	–	–	–	–



USER ("A") MENU

ENTERING THE USER MENU

1. Enter the Setup ("F") menu by following the directions above.
2. Use the right or left directional keys shown in Figure 3-3 to move right or left in the Setup ("F") menu until the indicator shows "A 1".

NAVIGATING IN THE USER MENU

1. Use the directional keys shown in the Figure to move around in the User Menu Chart.
2. To move to the selection level, press **ZERO/OFF** (down) key once. The current saved selection is shown.
3. To move to a new "F" heading, use **TARE** (left) or **ON/PRINT** (right) key to move right or left in the User Menu Chart.
4. If you want to go back without saving press **lb/kg**.
5. If a digit flashing, use **lb/kg** and **ZERO/OFF** for choosing value.
6. To save a new selection, press the **NET/GROSS** (Set) key. To exit without saving, press the **PRINT** (up) key to return to the current "F" heading.
7. You can cancel calibration anytime with switching back to normal mode. An alternative is to disconnect the power.

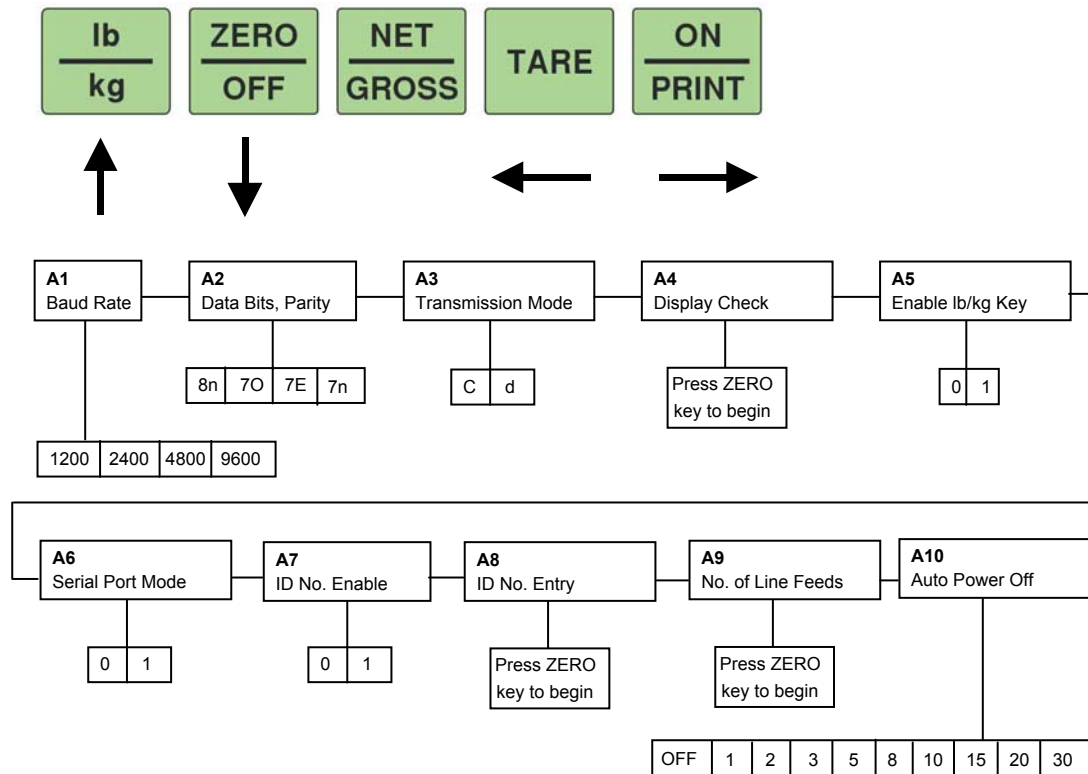

ID Number Entry (A8)

1. While in the User Menu mode, scroll to "A 8", then scroll down once using the ZERO key to enter the ID Number menu.
2. The display will momentarily show "ID NO", followed by a value with one flashing digit.
3. Use the four directional keys to adjust the displayed value to the actual ID Number value. Increase/decrease the flashing digit by pressing the **lb/kg** or **ZERO/OFF** key.
4. After setting the exact value, press the **NET/GROSS** key to save the ID Number value. The display will show "SET" momentarily, then revert back up to A8.

LF (Line Feeds) Number Entry (A9)

1. Go to "A9".
2. The display will momentarily show "LF", followed by the current line feeds value.
3. Use the four directional keys to adjust the displayed value
4. After setting the exact value, press the **NET/GROSS** key to save.

USER MENU DESCRIPTIONS AND PROCEDURES

Factory-set defaults are shown in **bold**.

NAME/CODE	DESCRIPTION	CODE/VALUE
A1 Baud Rate	Selects the baud rate for data transmission through the serial port.	1200 2400 4800 9600
A2 Data Bits and Parity	Selects the number of data bits and parity of serial transmission. "8n" = 8 data bits with no parity bit and one stop bit "7O" = 7 data bits with odd parity bit and one stop bit "7E" = 7 data bits with even parity bit and one stop bit "7n" = 7 data bits with no parity bit and two stop bits	8n 7O 7E 7n
A3 Mode of Serial Transmission	Selects when data will be sent out of the serial port to a printer or computer: "C" = Continuous mode; send data continuously "d" = Demand mode; send data when a PRINT command is issued from the printer, computer, or indicator.	C d
A4 Display Check	Actuates the function that illuminates all digit segments, decimal points, and LCD annunciators in a test sequence. Pressing the ZERO key to scroll down one level begins the test sequence.	Press ZERO key to begin sequence
A5 Disable the lb/kg Key	Allows the lb/kg key to be disabled so that an operator cannot accidentally press the key and change the displayed units. "0" = Disable the lb/kg key "1" = Enable the lb/kg key	0 (CE) 1 (US)
A6 Serial Port Mode	Selects the mode of the RS-232 serial port: Refer to Bilaga B for more information. "0" = Full Duplex Mode "1" = Print Ticket Mode	0 1
A7 ID No. Enable	Allows the ID number to be disabled in the Print Ticket mode. Valid only when A6 is set to "1". "0" = Disable the ID No. "1" = Enable the ID No.	0 1
A8 ID No. Entry	Actuates the function that allows entry of a new ID No. Valid only when A6 is set to "1". Pressing the ZERO key to scroll down one level begins the sequence.	0 - 199999 (500) 0 - 999999 (500E) 123456
A9 No. of Line Feeds	Actuates the function that allows entry of the desired number of line feeds to be printed in Print Ticket Mode. Valid only when A6 is set to "1". Pressing the ZERO key to scroll down one level begins the sequence.	0 - 99 5
A10 Auto Power Off Period	Selects the auto off time period in minutes: "Off" = Disabled (Always ON)	Off 1, 2, 3, 5 , 8, 10, 15, 20, 30



CALIBRATION

The indicator is calibrated by following the procedures embedded in F16 (Zero) and F17 (Span) of the Setup Menu.

Each procedure enters a value into the indicator's non-volatile memory - F16 the zero value (deadweight) and F17 the span value (test weight). The minimum test weight that can be used is 1% of full-scale capacity. After the two calibration procedures are executed successfully, you should record both calibration values using the F18 View procedure.

In the unlikely event that either value is lost while in the field, the setup menu makes provisions for re-entering these values via F19 and F20, thus eliminating the need for re-calibration with test weights.

NOTE: This chapter assumes that the indicator is in Setup ("F") Menu mode. If the indicator is not in Setup Menu mode, refer to Chapter 3 for instructions.

ZERO CALIBRATION (F16)

1. While in the Setup mode, scroll to "F 16", then scroll down once using the **ZERO** key to enter zero calibration menu. The display will momentarily show "C 0" followed by a value. This value is the internal A/D count and can prove useful when trying to troubleshoot setup problems.
2. After making sure that there are no test weights on the platform, press the **ZERO** key to zero out the displayed value.
3. Press the **NET/GROSS** key to save the zero point value. The display will show "EndC0" momentarily, then revert back up to F16. At this time, proceed to the F17 span calibration to complete indicator calibration.

SPAN CALIBRATION (F17)

1. While in the Setup mode, scroll to "F 17", then scroll down once using the **ZERO/OFF** key to enter span calibration menu.
2. The display will momentarily show "C 1" for the span calibration, followed by a value with one flashing digit. This value will be zero with the Decimal Point parameter selected in F10. Place the test weight on the weighing mechanism.
3. Use the four directional keys to adjust the displayed value to the actual test weight value. Increase the flashing digit by pressing the **lb/kg** key. Decrease the flashing digit by pressing the **ZERO** key. Pressing the **TARE** key or the **PRINT** key will change the position of the flashing digit.
4. After setting the exact value, press the **NET/GROSS** key to save the value.
5. If the calibration was successful, the display will show "EndC1" momentarily, then revert back up to F17. At this time it is suggested that the calibration values be recorded for future use.
6. If the calibration was *not* successful, one of the error messages below will appear. Take the indicated action to correct the problem, then perform a new calibration.

"Err0" The calibration test weight or the adjusted keyed-in weight is larger than the full capacity of the scale. Change the calibration test weight or check the input data.

"Err1" The calibration test weight or the adjusted keyed-in weight is smaller than 1% of the full capacity of the scale. Change the calibration test weight or check the input data.

"Err2" The internal resolution of the scale is not high enough to accept the calibration value. Select a larger parameter for the Span Gain (F2).

VIEW CALIBRATION VALUES (F18)

Note: The values displayed in this procedure are valid only after a successful calibration has been performed using F16 and F17.

1. While in the Setup mode, scroll to "F 18", then scroll down once using the **ZERO** key to enter View calibration menu.
2. The display will momentarily show "CAL 0" followed by a value. This value is the **zero calibration value** and should be recorded in the table below. Press any key to continue.
3. The display will momentarily show "CAL 1" followed by another value. This value is the **span calibration value** and should also be recorded in the table below. Press any key to return to upper level (F18).

INDICATOR	ZERO CALIBRATION VALUE	SPAN CALIBRATION VALUE
S/N:		

KEY-IN ZERO CALIBRATION VALUE (F19)

Note: This procedure is intended for emergency use only in the case of non-volatile memory loss. A valid zero calibration value, obtained from a successful F16 calibration procedure, must be used.

1. While in the Setup mode, scroll to "**F 19**", then scroll down once using the **ZERO** key.
2. The display will momentarily show "**CAL 0**", followed by a flashing zero. Use the four directional keys to adjust the displayed value to the zero calibration value.
3. After setting the exact value, press the **NET/GROSS** key to save the value.
4. The display will show "**E CAL 0**" momentarily, then revert back up to F19.

KEY-IN SPAN CALIBRATION VALUE (F20)

Note: This procedure is intended for emergency use only in the case of non-volatile memory loss. A valid span calibration value, obtained from a successful F17 calibration procedure, must be used.

1. While in the Setup mode, scroll to "**F 20**", then scroll down once using the **ZERO** key.
2. The display will momentarily show "**CAL 1**", followed by a flashing zero. Use the four directional keys to adjust the displayed value to the span calibration value.
4. After setting the exact value, press the **NET/GROSS** key to save the value.
5. If the entered value is greater than zero, the display will show "**E CAL 1**" momentarily, then revert back up to F20. If a value of zero is entered, the indicator will briefly show "**Err 5**", then revert back to the screen described above in Step # 2.



SPECIFICATIONS

ANALOG SPECIFICATIONS

Full Scale Input Signal	30 mV, including dead load
Minimum Sensitivity	1.0 uV / grad
Input Impedance	30 Mohm, typical
Internal Resolution	Approximately 150,000 counts
Display Resolution	50,000 display division max
Measurement Rate	10 Meas/sec, nominal
System Linearity	Within 0.02% of FS
Calibration Method	Software Calibration, with long term storage in EEPROM
Excitation Voltage	+5 VDC, 4 x 350 ohm load cells

DIGITAL SPECIFICATIONS

Microcomputer	Winbond W78E58
Program Memory:	32K x 8, internal to uC
SRAM	256 x 8, internal to uC
EEPROM:	256 x 8, external to uC
Digital Filtering	Software selectable

SERIAL COMMUNICATIONS

Serial Port	Full Duplex, 1200, 2400, 4800, 9600 Baud
	8 data bits, no parity, 1 stop bit
	7 data bits, odd parity, 1 stop bit
	7 data bits, even parity, 1 stop bit
	7 data bits, no parity, 2 stop bits

OPERATOR INTERFACE

Display	0.75" (19 mm) 7-segment, Liquid Crystal, 6-Digit
Additional Symbols	Net, Gross, Stable, Tare, lb, kg, Zero
Keyboard	5-key flat membrane panel

POWER

Rechargeable Battery	6 VDC, 3.0 Ah Sealed lead acid (e.g. Yuasa NP3-6 Dimension H67 x W134 x D34 mm)
AC Adapter	9 VDC, 800 mA
DC Power Consumption	55 mA + 15 mA/350 ohm Load Cell

ENVIRONMENTAL

Operating Temperature	-10 to +40 grad C
Storage Temperature	-25 to +70 grad C

MECHANICAL

Overall Dimensions (with stand)	10.4" x 7.5" x 2.9" (265 mm x 191 mm x 73 mm)
---------------------------------	---



SERIAL PORT INFORMATION

FULL DUPLEX MODE

The Full Duplex Mode provides a Demand serial transmission mode and is selected by setting A3 to “d” and A6 to “0”. The Demand mode allows control from a host device, usually a PC, and can be activated by pressing the PRINT key on the indicator’s front panel. Figure B-1 shows a suggested cable diagram for interface to a PC. Figure B-2 shows the serial data format for the Demand Mode.

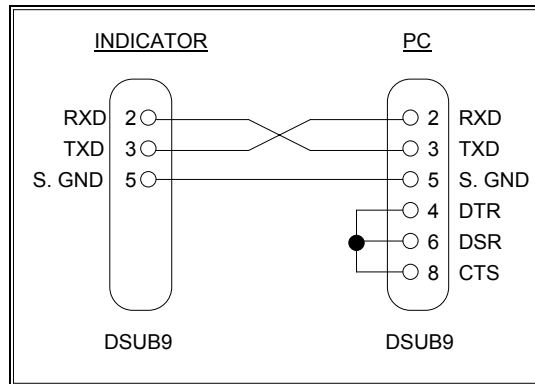

FIGURE B-1. Cable Diagram for Indicator to IBM PC

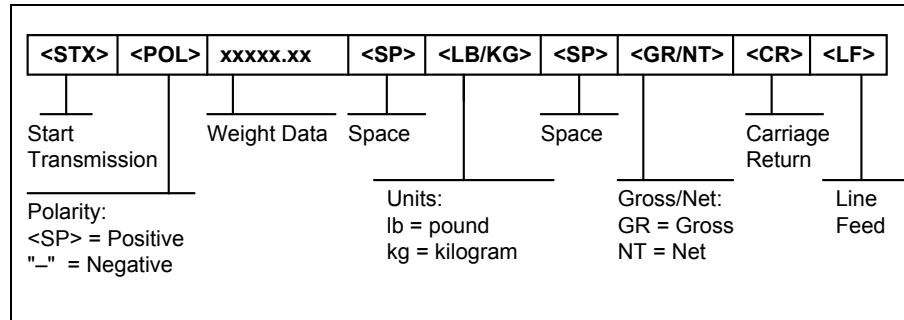

FIGURE B-2. Consolidated Controls Demand Mode

RECOGNIZED HOST COMMANDS

- “P” - This command is sent to the indicator to print the indicated display. The indicator will not respond if the scale is in motion, positive overload or negative overload.
- “Z” - This command is sent to the indicator to zero the scale. The indicator will not respond if the scale is in motion, positive overload or negative overload. The indicator will also not respond if it is not in gross mode or within the zero range specified in F4 of the Setup Menu.
- “T” - This command is sent to the indicator to tare the scale. The indicator will not respond if the scale is in motion, positive overload or negative overload. The indicator will also not respond if it displaying a negative gross value.
- “G” - This command is sent to the indicator to revert to gross mode. The indicator will not respond if the scale is in motion, positive overload or negative overload. The indicator will also not respond if it is not in net mode.
- “N” - This command is sent to the indicator to revert to net. The indicator will not respond if the scale is in motion, positive overload or negative overload. The indicator will also not respond if it is not in gross mode or a tare has yet to be established.
- “C” - This command is sent to the indicator to toggle among the configured units.

PRINT TICKET MODE

The Print Ticket Mode is designed specifically for a serial printer and is selected by setting A6 to "1". Figure B-3 shows the fixed format of the print ticket.

For printers with limited buffers, this mode supports DTR pin handshaking. The DTR pin from the serial printer is wired to the indicator's RXD pin which then functions as a CTS pin. Figure B-4 shows a suggested cable diagram for interfacing to a serial printer. Refer to the printer's user manual to confirm which pin is the DTR pin.

NOTES:

1. The TARE and NET fields are not printed unless a tare has been established in the system.
2. The ID number field is not printed if it is disabled in A7 of the User Menu.

ID. NO.	123456
GROSS	25.00 LB
TARE	1.48 LB
NET	23.52 LB

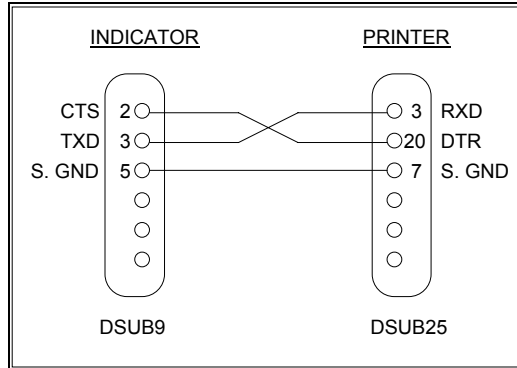

FIGURE B-3. Print Ticket

FIGURE B-4. Cable Diagram for Indicator to Printer

SIMPLEX MODE

The Simplex Mode provides a continuous serial transmission mode and is selected by setting A3 to "C" and A6 to "0". The Continuous mode is used to interface to computers, scoreboards, and other remote devices requiring constant data updating. The transmission occurs at the end of each display update. Figure B-5 shows the serial data format for Continuous Mode.

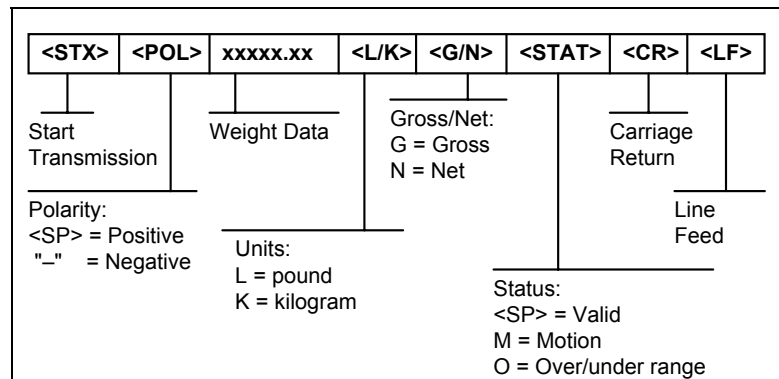



FIGURE B-5. Consolidated Controls Continuous Mode

DISPLAYED ERROR CODES

CODE	MODE	MEANING / POSSIBLE SOLUTION
□□□□□□	Normal Operating Mode	Gross Overload. A weight greater than the rated capacity has been applied to the scale. Remove the weight from the platter or try re-calibrating the scale. Otherwise, check for a bad load cell connection or possible load cell damage due to overloading.
	Normal Operating Mode	Indicates that the battery voltage is too low for normal operation. Re-charge the battery.
Err 0	Span Calibration Mode (F17)	Keyed-in weight value is larger than full scale capacity. Use a smaller test weight or check keyed-in value.
Err 1	Span Calibration Mode (F17)	Keyed-in weight value is less than 1% of full scale capacity. Use a larger test weight or check keyed-in value.
Err 2	Span Calibration Mode (F17)	There is not enough load cell signal to produce the internal counts necessary to properly calibrate the scale. First check all load connections. Use F16 mode to view internal counts. See Appendix C for more information.
Err 3	All Modes	Non-volatile memory read error. One or more setup parameters have been lost.
Err 4	All Modes	Non-volatile memory write error. Indicator needs service.
Err 5	Key-in Span Calibration Mode (F20)	You have attempted to enter a zero value for C1. Enter a known calibration value greater than zero.
Err 7	Initialization	No reading from the ADC. Make sure there is a load cell(s) connected to the indicator at start-up.
Err 9	Normal Operating Mode	Span calibration value has been lost. Re-calibrate the scale.

Fault localization

If it is a problem to get a reading on the display or it is important to calibrate. This instruction is valid for Loadcells with Sensitivity 2 mV/V

1. Check the excitation voltage (E+ and E-) from the Indicator. Should be 5,0 (+-0,2) VDC.
2. Check the input to the Indicator (S+ and S-). Should be approx 0 to +10 mV for the capacity range for above model of Loadcells. Note S+ is plus and S- is minus. The polarity is important.
3. If the input is wrong, <0 mV or > +10 mV with unloaded Scale check the Loadcells individually. Do not have only E+ and E- connected (or probably an external Power 5 VDC) and check the output from the Loadcells directly on the wires. Should be 0 mV to +10 mV depending on the load. (If you have external power e.g. 12 VDC the output should be 0 mV to +24 mV).
4. If all Loadcells seem to be okay connect all parallel to the Indicator and try to calibrate again. If it is not possible check the input S+ and S-. It should be an average value of all Loadcell outputs.

OPERATION

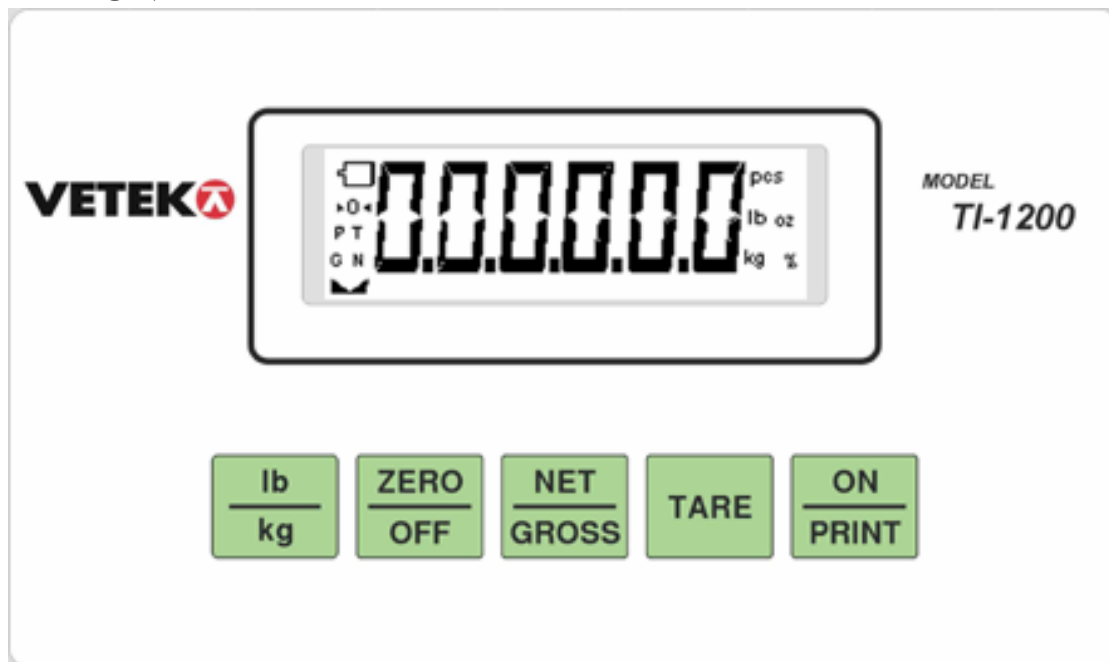

LCD Annunciator	MEANING
→0←	Better known as the “Center of Zero” annunciator, this light is active whenever the displayed weight is within ± 0.25 divisions of true zero.
N	Indicates that the indicator is displaying net weight.
G	Indicates that the indicator is displaying gross weight.
T	Indicates that a tare weight has been established in the system.
lb, kg	Indicates the unit of the displayed weight.
	Indicates a low battery condition. Re-charge the battery.
▶ ◀	Indicates stable reading

KEYBOARD

The keyboard is composed of five function keys.



FUNCTION KEYS

lb/kg – This key toggles the indicator between lb and kg units if enabled in the User (“A”) Menu

Zero - This key sets the indicator to display zero provided the following conditions are met:

1. The indicator is displaying Gross weight.
2. The displayed weight is within the zero reset range that is programmed in F4 of the Setup (“F”) Menu.
3. The scale is not in motion.
4. The scale is not in overload.

NOTE: When the ZERO key is held for three seconds, it shuts the indicator off.

Net/Gross - This key toggles the indicator between Gross weight and Net weight only if a Tare has been established.

Tare - This key is used to establish a Tare provided the following conditions are met:

1. The indicator is not at or below Gross zero.
2. The scale is not in motion.
3. The scale is not in overload.

Print - This key is used to send weight information out to the serial port provided the following conditions are met:

1. The scale is not in motion.
2. The scale is not in overload.

NOTE: When the indicator is off, the PRINT key is used to turn the indicator on.

GENERAL SCALE OPERATION

WEIGHING AN ITEM

1. Select the desired weighing unit by pressing the lb/kg key until that unit is indicated on the display.
2. If necessary, press the ZERO key to obtain a weight reading of zero.
3. Place the object to be weighed on the scale’s platter and allow the weight indication to stabilize. If the item weight exceeds the scale’s weight capacity, it displays “□□□□□□”.
4. Read the weight shown on the display.

TARING AN ITEM

To weigh an item in a container, the weight of that container must first be subtracted from the overall weight to obtain an accurate weight reading. This is known as taring.

1. Select the desired weighing unit by pressing the lb/kg key until that unit is indicated on the display.
2. If necessary, press the ZERO key to obtain a weight reading of zero.
3. Place the empty container on the scale’s platter and allow the weight indication to stabilize.
4. Press the TARE key. The display shows zero weight and turns the NET annunciator on.
5. Place the material to be weighed in the container and allow the weight indication to stabilize.
6. Read the weight shown on the display.

You may toggle between the gross weight and the net weight by pressing the NET/GROSS key.